

LED Dazzler

Intelligent LED Controller

Intelligent RGB LED HL1606 Controller / Effects Generator

The **LED Dazzler** is a very complex, yet simple design to control HL1606 based LED ribbon. Using minimal components, the **LED Dazzler** controls LED ribbons, at 5 volts, of any size up to and beyond 5m (16+ feet) or more, producing a full color halo in stunning display patterns and sequences.

Original design and software is based on an article by John Cohn posted as an Instructable (www.instructables.com/id/Too-cool-Rainbow-Headband/).

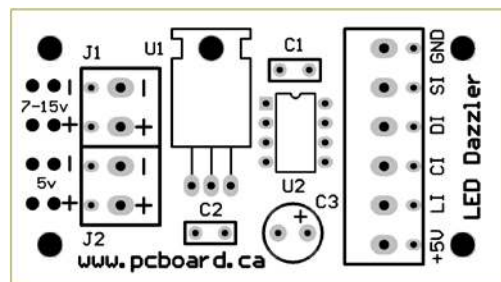
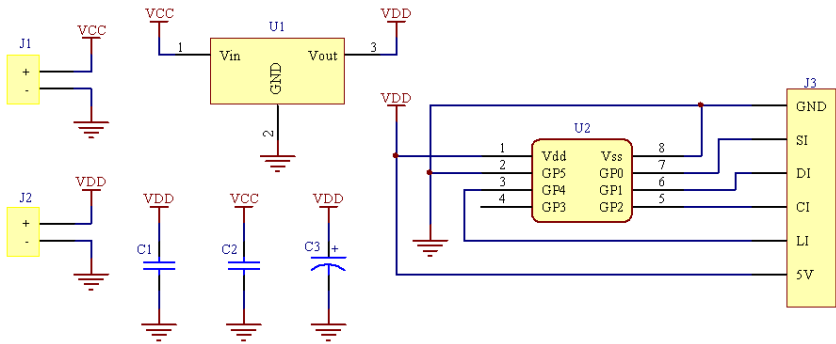

On the LED ribbon is an embedded processor to drive two RGB LEDs, controlling color, intensity and effects for the pair of LEDs. The **LED Dazzler** simply sends instructions to the embedded controller on the LED ribbon which in turn controls the LEDs.

The processor used on the **LED Dazzler** is a **PICAXE 08-M** 8-pin microcontroller which has the preprogrammed code stored in it which contains not only the lighting sequences, but also the base code necessary to control the LED

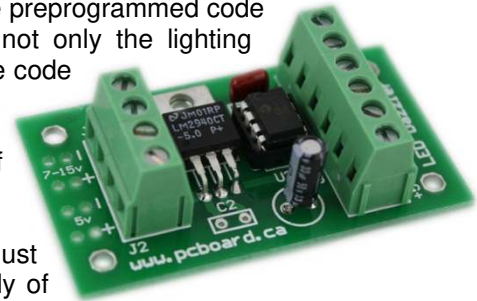

ribbon. The processor is reprogrammable with your own sequences providing you have an inexpensive programmer setup capable of programming the PICAXE 08-M.

The **LED Dazzler** is available fully assembled, as a kit you can build, or just the bare board allowing you to supply your own components. Assembly of the kit in less than 15 minutes is possible. The board is a high quality, double-sided design, complete with solder masks on both sides, plated holes along with a high-contrast silk-screen labeling component positions measuring only 2.5" x 1.4" (64mm x 36mm). Power input and connection to the LED Ribbon is through high-quality rising clamp terminal blocks which simplify connections to the board or optionally soldering directly to the PCB.

Component List

Capacitors:

[] (1) .1uF **C1**

Semiconductors:

[] (1) LED Dazzler PICAXE-08M Processor **U2**

Sockets and Connectors:

[] (1) 8-pin DIP Socket **U2**

[] (3) Rising Clamp Terminal Block. **J1, J2, J3**

PC Board:

[] (1) LED Dazzler Controller PCB **PCB**

7v – 15v DC Operation - Optional Components:

Semiconductors:

[] (1) LM2940CT-5.0-ND TO-220 Case **U1**

Capacitors:

[] (1) .47uF **C2**

[] (1) 33uF 50v Electrolytic Capacitor..... **C3**

Connectors:

[] (1) 9v Battery Connector..... **J1**

Power Supply Requirements

The **LED Dazzler** natively requires 5v DC to power the processor and also the LED Ribbon. The processor draws very little current, while the ribbon consumes most of the power up to a maximum of 120mA per 62.5mm (2.45") length while driving the units at full output. Most of the time, current draw per length is well below 50mA due to the fading and effects active.

The preferred power supply option for the **LED Dazzler** is to provide regulated 5v DC to the input connector **J2**. This allows you to provide sufficient power to drive larger LED Ribbon displays. Keep in mind that your supply voltage should not exceed 5.2v DC, exceeding this limit could result in erratic operation or permanent damage to either the processor on the board or to your LED Ribbon display.

Note: If you supply 5v directly to the board, **DO NOT** install the LM2940 voltage regulator **U1**.

9v Battery Operation

The **LED Dazzler** will run amazingly well and for many hours with an inexpensive 9v battery to short lengths of LED Ribbon. We have personally constructed many units that have run on a 9v battery to 1/2 meter (18 inches) of LED Ribbon and have operated in excess of 6 hours using inexpensive dollar-store batteries.

Running longer lengths of LED Ribbon is possible although you will find voltage regulator **U1** will run warm and may require a heat sink based on the current requirements.

If you choose to run on battery power, install the **7v – 15v DC Operation - Optional Components** as listed in the Component list. These components include the regulator **U1**, capacitors **C2** and **C3** and power to the PCB at **J1**. The 9v battery power connector has two leads, one black and the other red. The red lead is the positive connection while the black lead is negative. The positive (red) lead should be connected into the '+' marking on the board at the **7v – 15v** position on the board, while the negative (black) would go to the terminal labeled '-'.
7v – 15v DC Operation - Optional Components

5v DC High-Current Operation

The **LED Dazzler** can easily run much longer LED Ribbons. To do this, you must supply regulated 5v to the board labeled 5V '+' and '-'. Components **U1**, **C2** and **C3** must not be installed when running on 5v.

Operation

When powered up, the **LED Dazzler** will run the preprogrammed sequences already coded into the processor. You have the ability to customize the sequences on the **LED Dazzler**, but it does require the PICAXE programming software (available as a free download). The code will cycle through the various routines included and restart when it reaches the end.

LED Ribbon – Sources and Information

There are various sources of HL1606 based LED Ribbon other than through *PCBoard.ca*. With the design of this controller, you must utilize 5v based ribbon (there is 12v based ribbon available also, but it will not work with our configuration). Also, when connecting your ribbon to the **LED Dazzler**, you need to ensure you are connecting to the input of the ribbon and not the output. The LED ribbon input will be labeled with the following: *GND, SI, DI, CI, LI* and +5. The output, which can be used to chain to the input of another string would be labeled as: *GND, SO, DO, CO, LO* and +5.

Interfacing With Other Technologies

The implemented design is based around the PIC AXE microcontroller and begins to show the capabilities of the HL1606 Ribbon strips. There are pre-compiled libraries available for other microcontrollers, including a very powerful open source Arduino library.

Share Your Effects!

The versatility and strength of the **LED Dazzler** is its open architecture. If you have a lighting sequence you have created that you would like to share with others, please contact us and we can include it as a download from our site.

Connecting LED Dazzler to Digitally Addressable LED Ribbon

